



# Faster & Powerful

Adventurer 4 **Pro**



**Adventurer 4 Pro** retains the features of Adventurer Series, such as out-of-the-box design and easy printability, and further optimizes various functions to deliver higher-level printing quality. With the upgraded 9-point automatic leveling system, 2X faster printing speed, model cooling fans at both sides, and the support for various materials, it provides an efficient and easy-to-use experience for individuals, families and educational users.



**9-point Auto-Leveling**



**Standard Speed 100mm/s [2X faster]**



**PEI Flexible Steel Plate Platform**



**265°C Quick-release Nozzle**



**50db Quiet Printing**



**HEPA 13 Air Filter**



**Support PLA/ABS PETG/PLA-CF PETG-CF**



**Online Integrated Multi-machine Management**



## Efficient and Handy Worry-free Printing

### 9-point Automatic Leveling

It adds the function of automatic leveling detection compensation of the extruder sensor; Through 9-point detection of the relative height between the nozzle and the platform, intelligent compensation is performed in the printing process to ensure neat and smooth first-layer line extrusion.

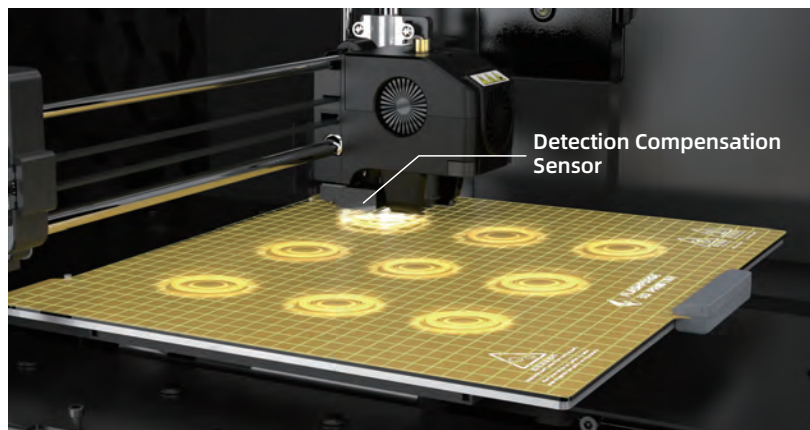

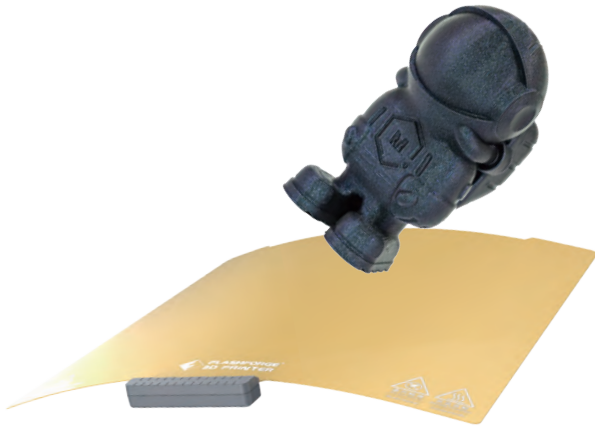

### PEI Flexible Steel Plate Platform, Offering Quick Model Removal

Without the use of tools, the model can be removed in 1 second through the bending platform. The build platform adopts PEI coating with strong adhesion, which prevents the first layer from warping; The bottom surface is more delicate and smooth.

**2X** Faster  
Printing Speed

**200mm/s**  
Maximum Printing Speed

**63%**  
Printing time shortened



### All-round Upgrade Superior Surface Quality

#### Brand-new Extruder Fan Structure

The extruder is equipped with 3 fans to control the cooling wind speed. The dual ducts achieve the rapid cooling of the models, offering better surface finish.

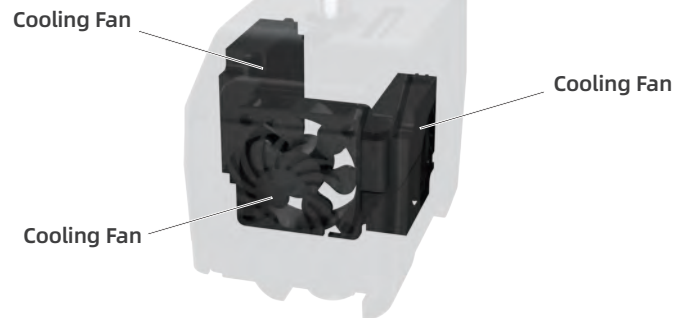

### 265°C Copper Nozzle & Hardened Nozzle

The standard 0.4mm-265°C copper nozzle with great thermal conductivity matches fast printing; The upgrade of internal thermal conductivity ensures the model quality under high-speed printing. An optional 0.6mm high-strength nozzle with wear-resistant features supports long time printing of carbon fiber materials.



# Parameters

Extruder Quantity	1
Printing Precision	±0.1mm [ Testing based on 100mm cubes ]
Build Volume	220 x 200 x 250mm
Nozzle Diameter	0.4mm [Default] [ 0.6/0.3mm Optional]
Nozzle Type	High-strength nozzle / Copper Nozzle
Printing Speed	Standard Speed 100mm/s; Maximum Speed 200 mm/s
Maximum Extruder Temperature	265 °C
Maximum Platform Temperature	110 °C
Supported Filament	ABS / PLA / PETG / Silk / PLA-CF / PETG-CF
Power Supply	AC100-240V / DC 24V / 13.3A, 320W
Equipment Dimensions	500[L] x 470[W] x 540[H] mm
Package Dimensions	580[L] x 570[W] x 630[H] mm
Slicing Software	FlashPrint
Connectivity	USB Flash Drive / Wi-Fi
Certification	CE / FCC / RoHS
Operating Ambient Temp.	15-30 °C
Leveling	Auto-leveling [9-point leveling]
Air Filter Net	HEPA 13
Flexible & Removable Build Plate	PEI Steel Plate
Other Features	<input checked="" type="checkbox"/> Filament Run-out Reminder <input checked="" type="checkbox"/> Camera <input checked="" type="checkbox"/> Power Loss Recovery <input checked="" type="checkbox"/> Quiet Printing

## Zhejiang Flashforge 3D Technology Co., Ltd.

Tel: +86 579 82273989   Email: support@flashforge.com  
No.518 XianYuan Road, Jinhua City, Zhejiang Province, China

